



Model 1221 DAS Public Safety Annunciator Panel *Installation Instructions*

11/1/24 Rev F

Sales @dasalert.com



Technical Support
Phone: (303) 526-1965
8:00 AM – 5:00 PM (Mountain)

CONTENTS	PAGE
Warnings and Cautions	4
Compatibility.....	5
Main PC Board.....	5
LED Panel Indicators.....	8
Installation.....	9
Fire Panel Connections.....	10
Buzzer.....	10
Panel Backup AA Batteries.....	13
Bias-T Detection of Donor Antenna Disconnection.....	13
Lightning and Surge Protection.....	13
Self-Test and Trouble Shooting.....	13
Connecting Multiple Panels.....	14
DIP Switch Settings.....	14
Specifications.....	25

Figures and Tables

Included Items.....	5
Figure1. Included Items.....	6
Figure 2. Alarm Connections and DIP Switch Settings.....	7
LED Functions.....	8
Figure 3. Wall Mounting Instructions.....	11
Figure 4. Optional Mounting Kits.....	12
Table 1. DIP Switch SW1.....	14
Table 2. DIP Switch SW2.....	14
Table 3. DIP Switches SW3 and SW4.....	15
Table 4. Factory Default DIP Switch Settings.....	15
Figure 5. Wiring Diagram from DAS Componenets if cable length is less than 20 feet.....	16
Figure 6. Wiring Diagram with two CAT 5/6 Cables if cable length is greater than 20 feet.....	17
Figure 7. Wiring Diagram with one CAT 5/6 Cable.....	18
Figure 8. Wiring Diagram with one CAT 5/6 Cable with no System Component and no Oscillation detection required.....	19
Figure 9. Wiring to Building's Fire Panel.....	20
Figure 10. Antenna Monitoring with Bias-T.....	21
Figure 11. Optional Alarm Splitter.....	22
Figure 12. Back of Door.....	23
Figure 13. Physical Dimensions.....	24

Warnings and Cautions that Must be Observed to
Maintain Warranty Protection and Ensure
Proper Operation

CAUTION: Do not try to enlarge the existing conduit ports as this will invalidate the warranty and may damage internal sensitive electronics. Use a 1/2" adapter / expander to mate with larger diameter conduit.

CAUTION: Use only 2500 mAh rechargeable NiMH batteries like the type that are included. Other AA types will cause corrosive damage to the battery holder. (see page 13)

CAUTION: Do not connect an AC voltage to J2. Damage will result.

CAUTION: Use standard 18-24 AWG wire or standard CAT 5 / CAT 6 cable to mate with the plugs. Heavier gauge wire tends to crimp and interfere with the ability to screw the panel door shut.

IMPORTANT: Alarm relay contacts in the DAS equipment must only be connected to the Panel. No other equipment (like the Fire Panel) can also be connected to these contacts. Otherwise both the DAS Alert Panel and Fire Panel will not operate properly.

IMPORTANT: For the static electric transient, ground loop surge and near-by lightning strike protections to be effective, the ground lug on the left side of the enclosure must be connected to a good earth ground. It is also recommended that all power supplies (including the one that is provided) be used with a surge protector providing at least 1000 joules protection.

Included Items (See Figure 1)

Included Items

QTY	DESCRIPTION
1	Model 1221 Annunciator Panel
8	8-Pin Plug
1	2-Pin DC Power Plug
1	2-pin Test Plug
2	2-pin Plug
1	48 VDC Wall Socket Mount power supply with 10 ' cable.
1	Screw driver for mating wires to plugs
4	AA 2500 mAh rechargeable NiMH battery
1	3/16" drill Bit
4	Drywall Anchors
4	Wall mounting screws #6 x 3/4"
10	10K 1% 0.25 watt end-of- line resistor (EOLR)
3	Wire ZIP tie
3	Wire tie mounting pad
2	Mute key
1	Wall Mount Drill Template
1	Instructions
9	Knockout Plugs

Tools Required

Electric Drill and #2 Phillips Screwdriver

Compatibility

This annunciator panel meets or exceeds all UL- 2524, IFC, NFPA & Local requirements. It is functionally backwards compatible with all previous versions of the Model 1221 series. It has an internal universal DC power converter that enables operation from any DC input voltage between 12 - 55 VDC..

Main PC Board

Figure 2 shows the layout of the main PC board and the locations of the DIP switches (shown in their factory default settings) and connector locations to be wired to the DAS equipment and the building's Fire Panel.

Figure 1. Included Items



Main Panel



8-pin plug, QTY: 8



DC Power Plug, QTY: 1



2-pin Test Plug, QTY: 1



Drywall Anchor, QTY :4



3/16" drill Bit , QTY: 1



6 x3/4" wall Mount Screws. QTY 4



Screwdriver for Plugs



AA rechargeable NiMH Batteries, Tenenergy Model 90403 (see page 13 for details) QTY 4



Wire mounting pad, QTY 3



ZIP Tie, QTY 3



10k 1% End-of-Line Resistors, QTY 10

48 VDC Power Supply with 10' output cord



2-pin Plug, QTY: 2



Mute Keys QTY 2



Knockout Plugs QTY: 9

Figure 2. Alarm Connections and DIP Switch Settings (shown in factory default)

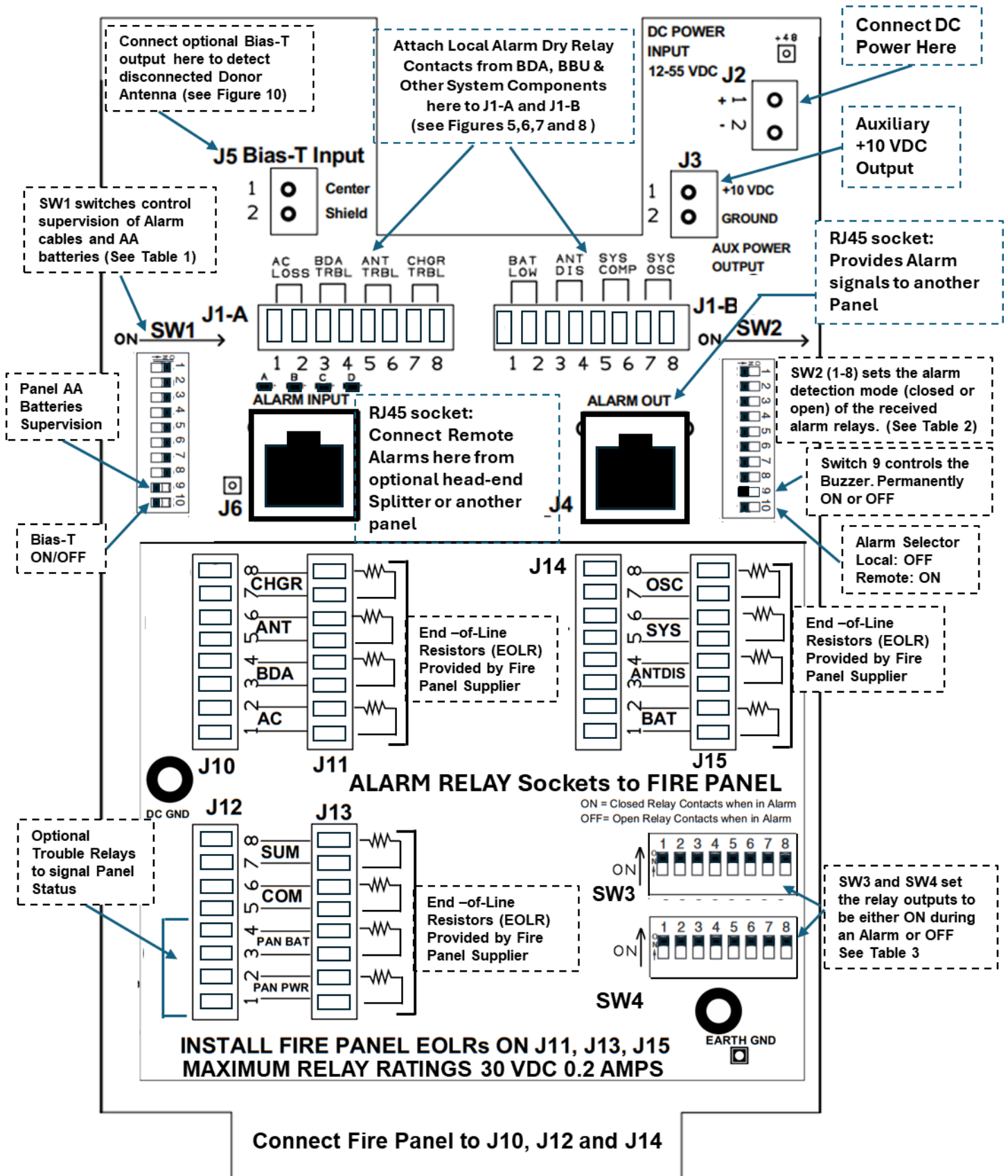

LED Panel Indicators

This annunciator panel has 9 LEDs on it showing the status of the equipment in the DAS. The functions are described below:

LED Functions

LED	DESCRIPTION
1	AC Power Normal (Green when AC power is on to the DAS Equipment.)
2	AC Loss (Normally OFF, Amber if AC power is down)
3	BDA Trouble (Normally OFF, Amber if there is a BDA problem)
4	Donor Antenna Trouble (Normally OFF, Amber if there is a problem)
5	Donor Antenna Disconnected (Normally OFF, Amber if the antenna is disconnected)
6	Battery Charger Alarm (Normally OFF, Amber if there is trouble)
7	Battery Capacity (Normally OFF. If the DAS backup battery has less than 30% capacity this LED is Amber)
8	System Oscillation (Normally OFF, Amber if the system is oscillating)
9	System Component Alarm (Normally OFF, If other system components have trouble alarms, this LED is Amber.)
10	Communications or Panel Trouble (Normally OFF, is Amber if the panel has any kind of problem such as its backup battery dead or a short to ground (or open) on any of the alarm wires connected to it from the DAS equipment.)

If there is a communications fault with one of the alarms, the specific alarm LED will designate the problem by flashing RED.

The **LED TEST button** on the front panel illuminates all of the LEDs on the front panel and the internal Panel status LEDs on the back of the front door. The alarm relays to the fire panel **are NOT** activated during this test.

Installation

1. Remove all of the pre-mated plugs, AA batteries, mounting Kit, end-of -line resistors (EOLR) and knockout plugs that are packed inside the Panel in plastic bags.
2. There are 9 conduit ports provided on the enclosure to accommodate a wide variety of installation configurations from the top, bottom, sides and back. These ports will accommodate standard ½” conduit fittings. If larger fittings are required, use an adapter / reducer that are available from many sources. **CAUTION: Do not try to enlarge the existing ports as this will invalidate the warranty and may damage internal sensitive electronics.**
3. Attach the required fittings to the panel and install the enclosed knockout plugs in any unused ports.
4. Use the enclosed mounting template to mark the location of the four mounting holes that should be drilled using the enclosed 3/16” drill bit.
5. Follow the directions shown in Figure 3 to mount the panel to a wall.

NOTE: There are several other ways to mount this panel using the optional accessories shown in Figure 4

6. Install the included AA batteries. **CAUTION: Use only rechargeable 2500 mAh NiMH batteries like the type that are included. Other AA types will cause corrosive damage to the battery holder and will invalidate the warranty. (see Page 13)** These batteries should be checked annually when the rest of the DAS is maintained, but typically, they should be good for up to 5 years. In the event of a primary power outage they will keep the Panel running for over 12 hours. When primary power is restored, typical recharge to full capacity is less than 12 hours.
7. DIP switch SW1 should be in the factory default mode with all switches ON except 9 and 10. DIP switch SW2 should be in the factory default mode with all switches OFF.
8. Attach the DC power to J2. **CAUTION: Do not connect an AC voltage to J2. Damage will result.** The DC power (any DC voltage between 12-55 volts) can be supplied from the included 48 VDC power supply or from the systems' Backup Battery Unit (BBU). The current consumption is very low (30mA @ 48 VDC), so the wires providing this power can be very long (5000 feet maximum).
9. Check that the AC POWER LED on the front door is illuminated GREEN and that all other LEDs are OFF. Check that the PANEL BAT LED and PANEL PWR LED on the back of the door are GREEN (see Figure 12). Check that the buzzer is not sounding.
10. At this point the wiring from the BDA, BBU can be connected to the Panel and can be tested to verify that everything is working correctly. There are several ways to connect to the Panel depending on the location of the various components, what kind of wiring has been pre-installed and how many alarms are available from the BDA and BBU. Figures 5, 6, 7 and 8 show these options. **Use standard 18-24 AWG wire or standard CAT 5 / CAT 6 cable to mate with the plugs. Heavier gauge wire tends to crimp and interfere with the ability to screw the panel's door shut.**

11. DIP Switch SW2 1-8 can be used to individually set the detection sense of the alarms from the DAS equipment. If the DAS equipment has relays that close (are shorted) when there is an Alarm the appropriate switch on SW2 should be OFF. If the relays in the DAS equipment are normally closed (shorted) when there is no alarm (not typical) and are open to indicate an Alarm, then the appropriate switch on SW2 should be ON. Table 2 shows this information. **IMPORTANT: The Alarm relay contacts in the DAS equipment must not be connected to other equipment (like the Fire Panel) otherwise both the DAS Alert Panel and Fire Panel will not operate correctly.** Normally the Fire Panel can be connected to the relays in the Panel located in the fire command center with no problems. But in some cases, it may be necessary to connect to outboard Fire Panel modules located in the DAS headend elsewhere in the building. In that situation use the optional splitter shown in Figure 11.
12. **Installation of End-of-Line Resistors (EOLR):** By code if any wires from the DAS equipment to the Panel are longer than 20 feet, then they must be 'supervised' to detect open circuits or short circuits. 10 k 1% resistors are provided to be installed as per Figures 6, 7 and 8 to comply with this requirement. If the wires are shorter than 20 feet, then the appropriate DIP switch on SW1 should be ON. (see Table 1).
13. **Any unused alarm inputs to J1-A should be turned OFF by placing the appropriate switch on SW1 to the ON position. (see Table 1).**
14. Once the initial alarm wiring is installed and verified, connect the building's Fire Panel as described in the following section.

Connections to the Fire Panel

There are several ways to connect to the building's Fire Panel or any outboard modules that are available. There are a total of 12 dry relays in the DAS Alert Panel available to communicate the status of the DAS and the Panel. These relays can be individually programmed to be either closed (shorted) when there is an Alarm or open when there is an Alarm. The factory default is that they will close indicating an Alarm. (This is the standard Alarm signaling required by most Fire Panels). Table 3 shows a list of these relays, their functions and the DIP switches that can be set to reverse their operation. Figure 9 shows the wiring diagram.

If all primary, secondary and AA backup battery power to the DAS Alert Panel is lost, all the relays will be closed.

The Fire Panel can also be connected to an optional splitter that can be located remotely in the DAS Headend (see Figure 11).

Buzzer

One of the requirements of UL-2524 is that an audible alarm be included as part of the Panel that can ONLY be silenced for up to 24 hours by a keyed switch. This requirement is to keep unauthorized people from turning the buzzer off. If the DAS Alert Panel is located close to the building's Fire Panel and it has an audible alarm triggered by the DAS alarms, then the DAS Alert buzzer can be permanently disabled by setting DIP Switch SW-2 (switch 9) to the OFF position.

The buzzer has three audible modes:

- It will sound once every 10 seconds if any alarm is triggered.
- It will sound once per second if there is a communications fault, or the Panel's backup AA battery pack is dead or not installed.
- ◆ It will sound continuously if there is no Alarm and the Mute Switch is ON for test purposes

Figure 3. Wall Mounting Instructions

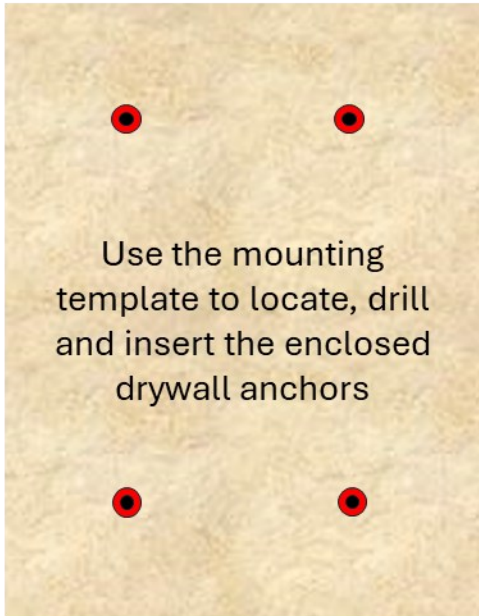

Screws will protrude through back of the enclosure

Use a # 2 Phillips screwdriver to tighten screws



Figure 4. Optional Mounting Kits

Flange Mounting Bracket Kit



Model FMB-1



Flush Mounted in a wall cavity with a Decorative Trim Plate



Model TRM-2

Panel AA Backup Batteries

This panel includes four rechargeable NiMH AA batteries to provide at least 12 hours of operation in the event of the loss of all AC primary power and loss of DC power from the BBU. **CAUTION: Use only rechargeable 2500 mAh NiMH batteries like the type that are included. Other types will cause corrosive damage to the battery holder and will invalidate the warranty.**

The provided batteries are high-capacity 2500 mAh rechargeable Nickel Metal Hydride (NiMH) types manufactured by Tenergy (Model 90430) and should be replaced at least every 5 years. They are low cost and are available from many sources. ([Tenergy 4 Pack 2500 mAh Batteries](#)) Please contact customer service if you need help locating suitable replacements. *We have no affiliation with Tenergy or AMAZON.*

Typically, they are replaced annually when the rest of the DAS is tested.

For the AA backup batteries to operate, DC primary power must be on first. After that, the battery power will cut in automatically if primary DC power is lost.

There is an internal charger keeping the batteries fully charged. The panel includes a low voltage cutoff switch that disconnects the batteries if they drain beyond a preset level. Once the battery pack reaches this level it typically requires up to 12 hours to recharge. If the batteries are not installed or are drained, an alarm is generated indicating panel trouble. An indicator LED inside the panel flashes RED when the panel primary DC power is off and the battery is providing power. There is an LED on a PC board attached to the back of the door above the battery holder that flashes RED if the batteries are dead or need to be installed.

If the Panel batteries are not required in your jurisdiction, are lost, or are not immediately available for replacement, the circuit monitoring these batteries can be disabled by placing DIP switch 9 on SW1 to the ON position.

Bias-T External Detection of Donor Antenna Disconnection

UL-2524 requires that if the outdoor donor antenna is disconnected an alarm should be triggered. If the BDA

All of the wire connections to and from the Panel are protected from high-voltage static electric, power surges and near-by lightning strikes. **For these protections to be effective the ground lug on the left side of the enclosure needs to be connected to good earth ground (see Figure 13).** It is also recommended that all power supplies (including the one provided) be used with a surge protector providing at least 1000 joules protection.

Self-Test and Trouble Shooting

A test connector is included inside the panel that can be used to simulate Alarm inputs to connectors J1-A and J1-B. The included 2-pin test connector can be used to independently check the panel and confirm its operation without any other DAS equipment connected.

To do the self- tests, remove plugs J1-A and J1-B. Set the DIP switches (SW1 and SW2) to their factory default settings shown in Figure 1. Confirm that all LEDs are OFF except **AC Power Normal** which should be GREEN. The test plug can be connected between the input ports on J1-A and J1-B to simulate alarm signals for each type of alarm. The corresponding AMBER LEDs on the front panel should illuminate for each type of alarm. **Do not discard this plug. Keep it in the panel to enable future trouble shooting and alarm simulation for the Fire Panel if required.**

Connecting Multiple Panels

For some installations it may be required to install multiple DAS Alert panels in a building or campus. J4 is an RJ-45 socket that provides a way to transmit on a standard CAT 5/6 cable all the received alarms and DC power from one Panel to another. To enable this mode of operation DIP switch SW2 #10 on the Panel receiving the alarms should be ON and the CAT 5/6 cable should be connected from J4 on the transmitting Panel to J6 on the receiving Panel.

DIP Switch Settings

Figure 2 shows the factory default DIP switch settings for SW1, SW2, SW3 and SW4.

The following tables show the detailed functioning of all the DIP switches:

Table 1. DIP Switch SW1

DIP SWITCH SW1 Simulates 10k EOLR Termination, Normally OFF, If cable length is shorter than 20 feet set the designated switch ON.	
Switch	DESCRIPTION
1	AC Loss
2	BDA Trouble
3	Donor Antenna Trouble
4	Charger Trouble
5	Battery Low
6	Donor Antenna Disconnected
7	Other System Component Trouble
8	System Oscillation
9	ON disables supervision of Panel's AA batteries
10	ON Enables external Bias-T Donor Antenna disconnection sense connected to J5

Table 2. DIP switch SW2

DIP SWITCH SW2 (switches 1-8) are used to set the Alarm Detection mode for the signals from the dry relay alarm contacts in the DAS equipment. If the relay closes (is shorted) when there is an Alarm, set the switch OFF. If the alarm relay is normally closed (shorted), but is OPEN when there is an Alarm, turn the switch ON.	
Switch	DESCRIPTION
1	AC Loss
2	BDA Trouble
3	Donor Antenna Trouble
4	Charger Trouble
5	Battery Low
6	Donor Antenna Disconnected
7	Other System Component Trouble
8	System Oscillation
9	OFF= Buzzer permanently disabled, ON = Buzzer active
10	ON=Selects Alarm signals from external source, OFF= Selects Alarm signals connected to J1-A and J1-B

Table 3. DIP Switches SW3 and SW4

Fire Panel Relays: Closed when in Alarm = ON, Open when in Alarm = OFF	
Switch	DESCRIPTION
SW3-1	AC Loss (Factory Default: ON)
SW3-2	BDA Trouble (Factory Default: ON)
SW3-3	Donor Antenna Trouble (Factory Default: ON)
SW3-4	Charger Trouble (Factory Default: ON)
SW3-5	Panel Power Fault (Factory Default: ON)
SW3-6	Panel AA Battery Fail (Factory Default: ON)
SW3-7	COMM Trouble (Factory Default: ON)
SW3-8	Summary Alarm (Factory Default: ON)
SW4-1	DAS Battery Low (Factory Default: ON)
SW4-2	Donor Antenna Disconnected (Factory Default: ON)
SW4-3	Other System Component Trouble (Factory Default: ON)
SW4-4	System Oscillation (Factory Default: ON)

Table 4. Factory Default DIP Switch Settings

DIP SWITCH SW1	
SW	Factory Default
1	ON
2	ON
3	ON
4	ON
5	ON
6	ON
7	ON
8	ON
9	OFF
10	OFF

DIP SWITCH SW2	
SW	Factory Default
1	OFF
2	OFF
3	OFF
4	OFF
5	OFF
6	OFF
7	OFF
8	OFF
9	OFF
10	OFF

DIP SWITCH SW3	
SW	Factory Default
1	ON
2	ON
3	ON
4	ON
5	ON
6	ON
7	ON
8	ON

DIP SWITCH SW4	
SW	Factory Default
1	ON
2	ON
3	ON
4	ON
5	ON
6	ON
7	ON
8	ON

**Figure 5. Wiring Diagram from DAS Components if cable length is less than 20 feet
(set switches 1-8 ON on DIP Switch SW1)**

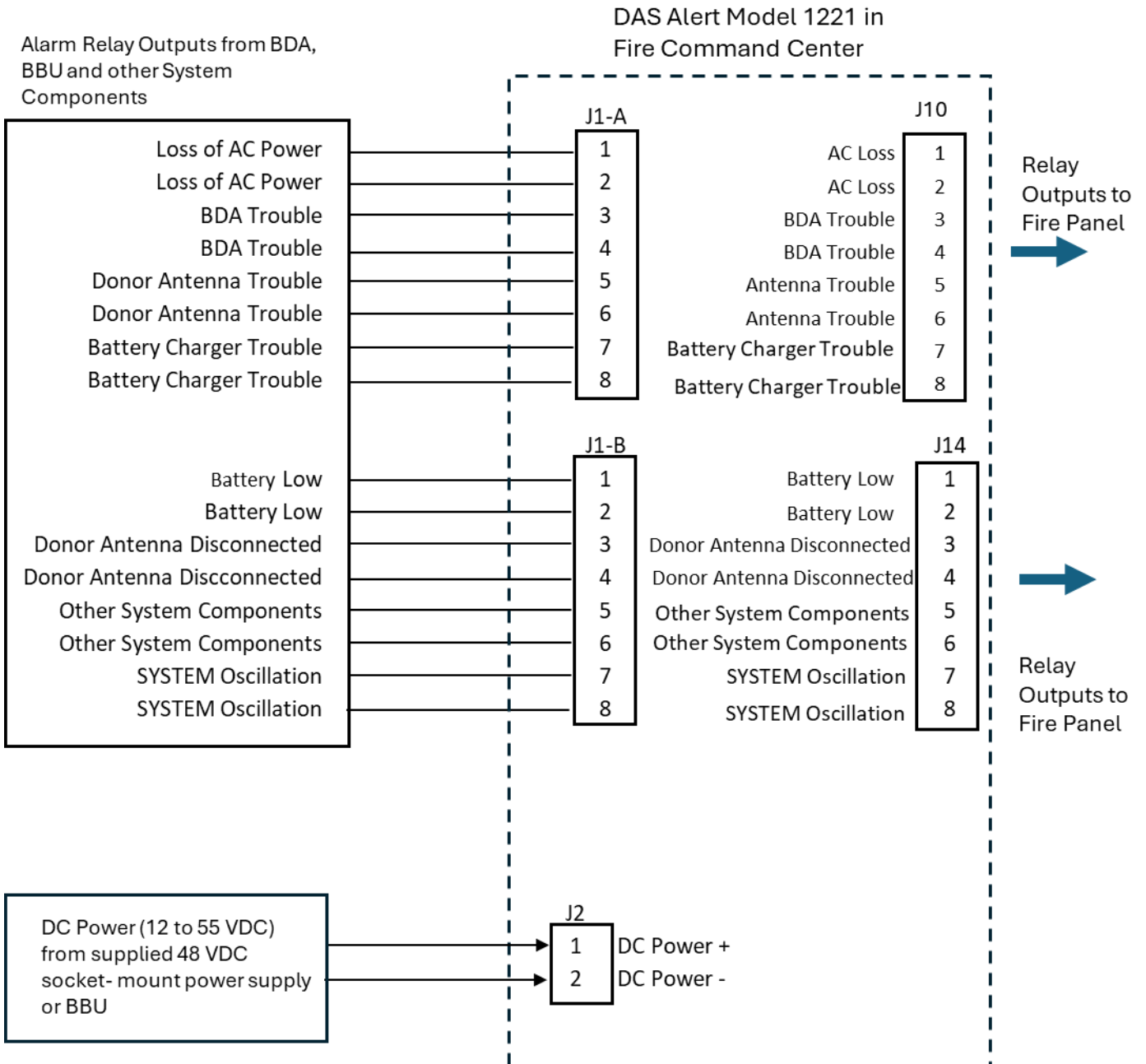
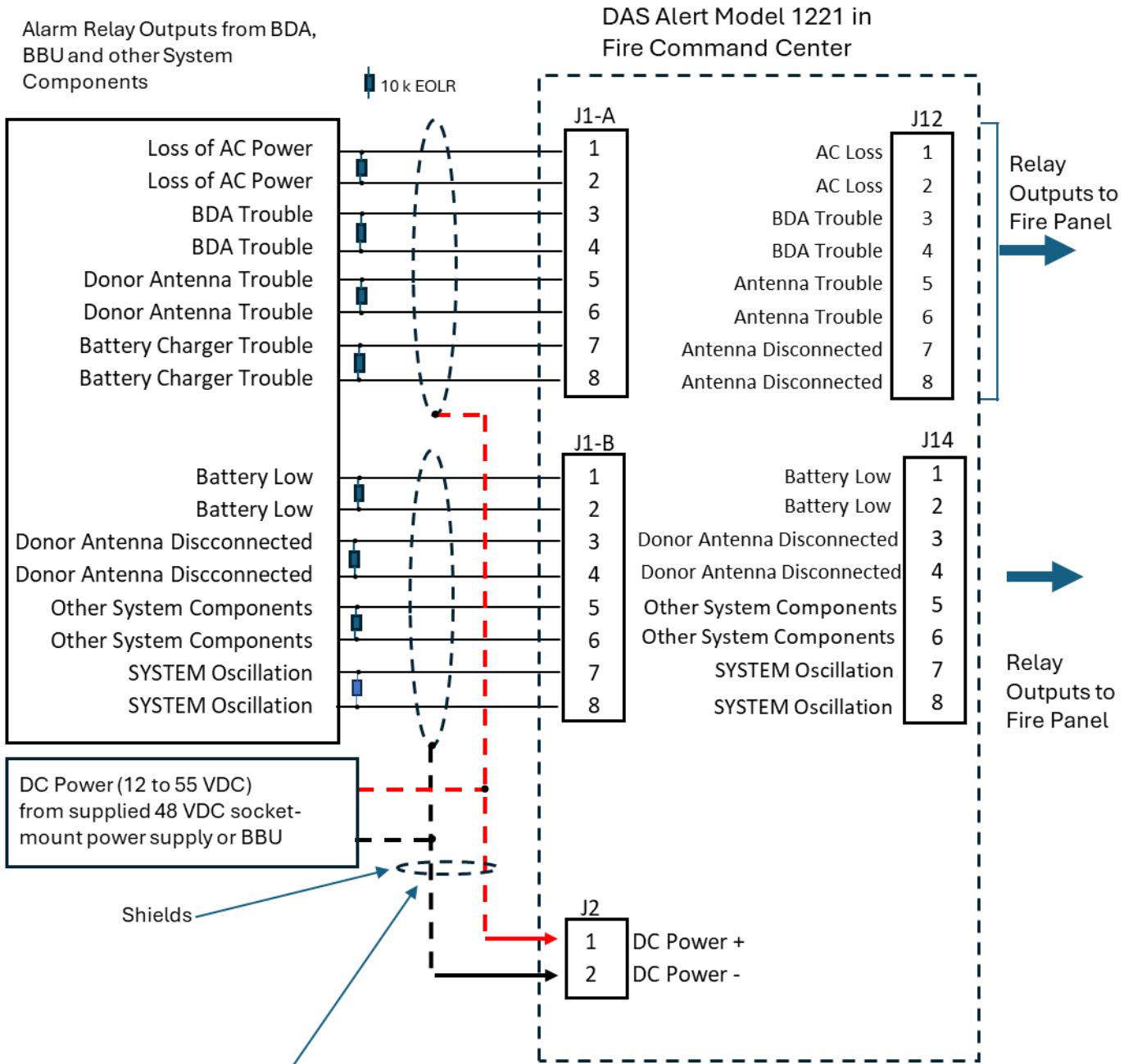
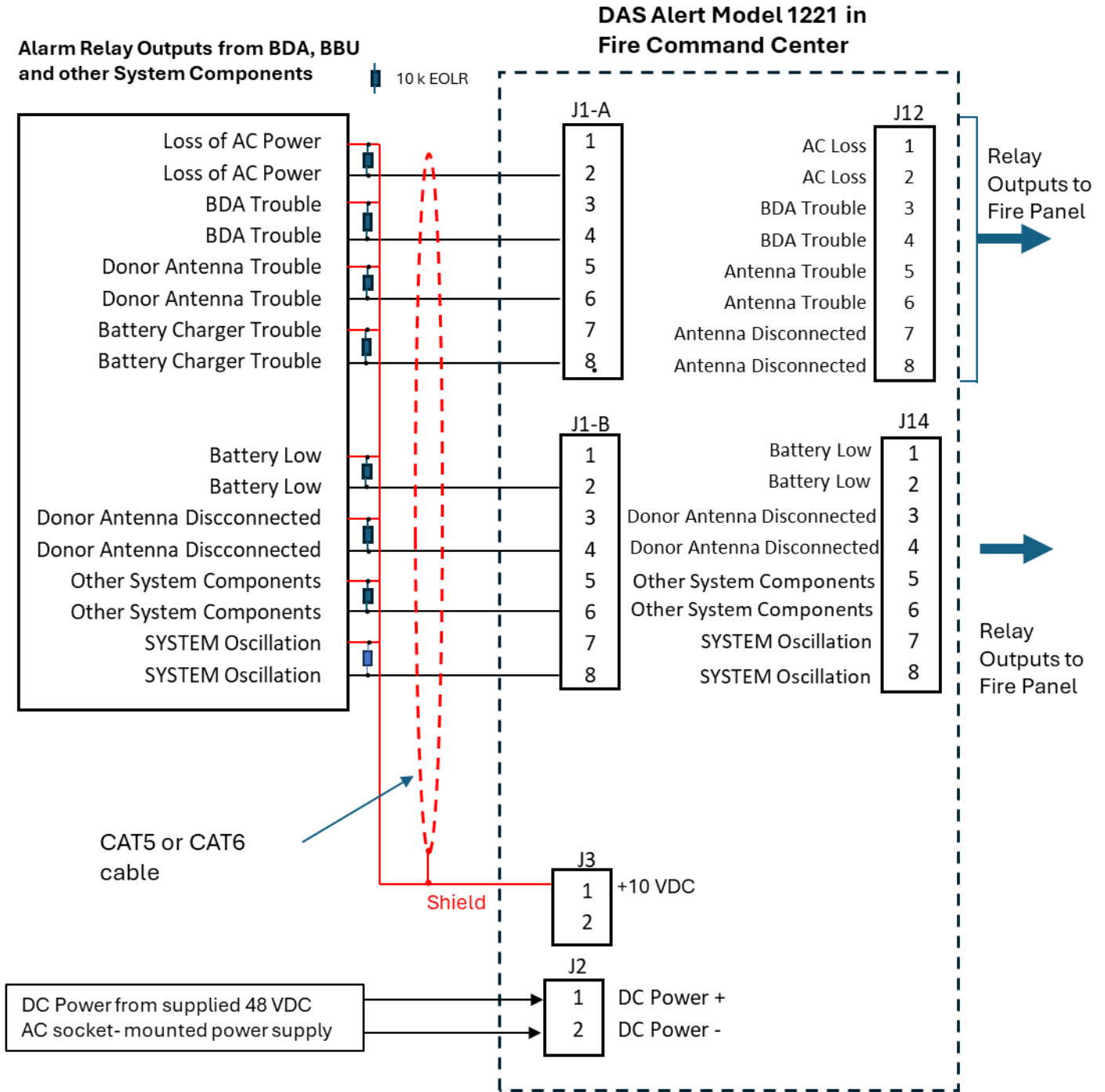

Figure 6. Wiring Diagram with two CAT 5/6 cables if cable length is greater than 20 feet (set switches 1-8 to OFF on DIP Switch SW1)



If it is desired to locate the power supply remotely with the BDA and BBU, the optional wiring for DC power can be made using the isolated shields of the CAT 5/6 cables.

**Figure 7. Wiring Diagram with one CAT 5/ 6 cable (set switches 1-8 to OFF on DIP Switch SW1)
DC power supply located in Fire Command center**



**Figure 8. Wiring Diagram with one CAT 5/6 cable.
 For installations where there is no System Component,
 and no Oscillation detection required.
 (Set all switches on SW1 to OFF except 7 and 8)**

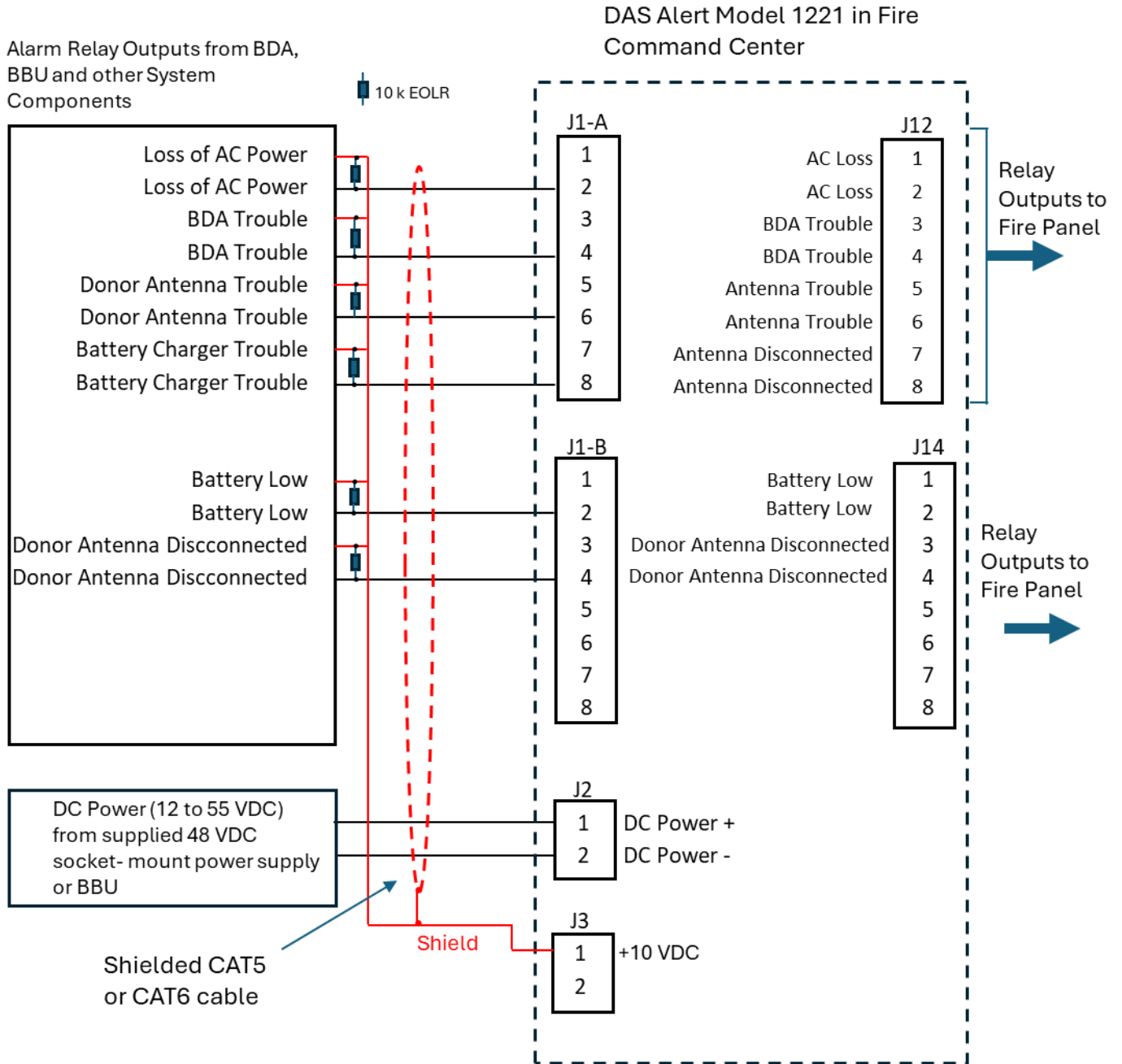
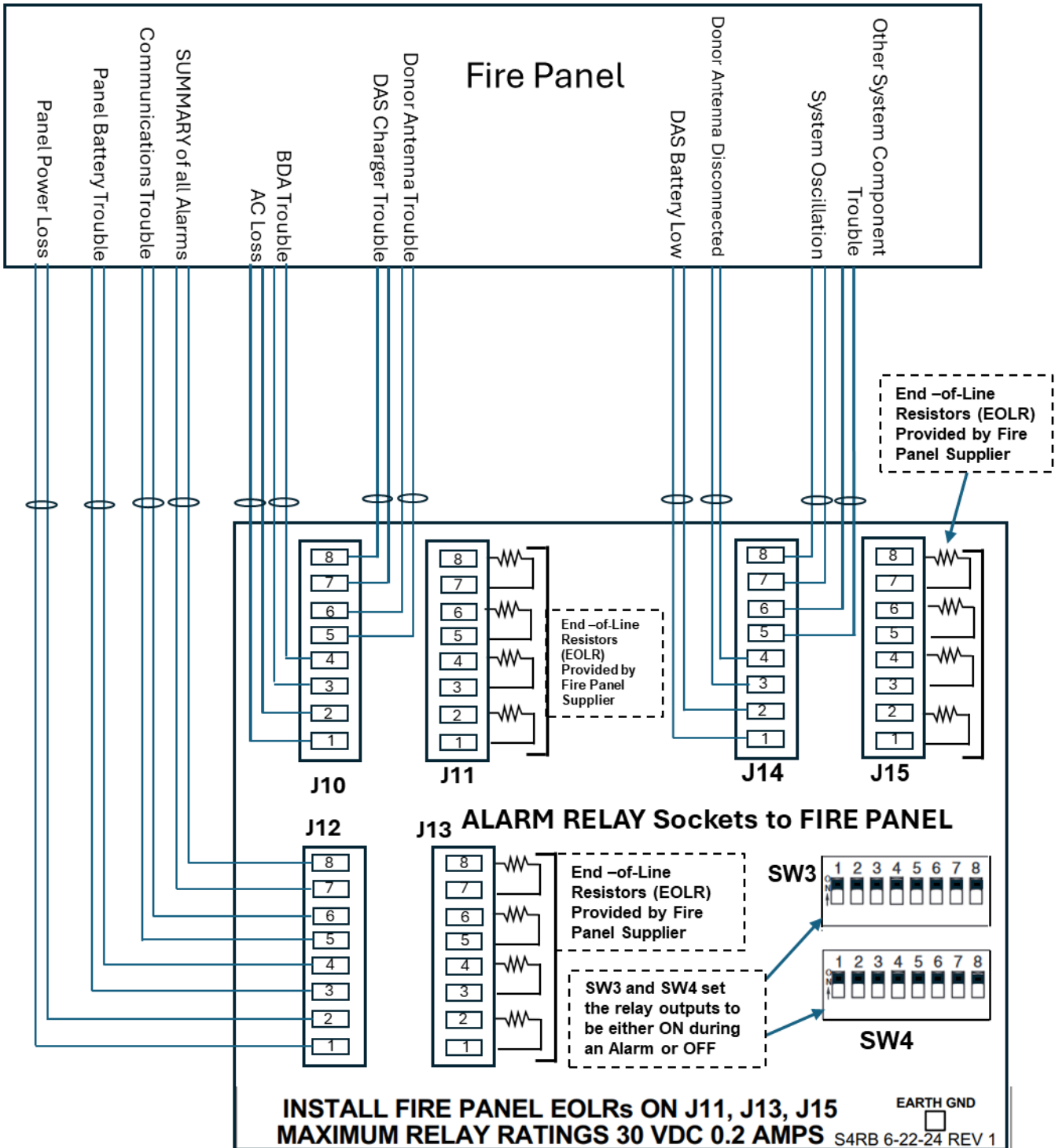

Figure 9. Wiring to Building's Fire Panel



Connect Fire Panel to J10, J12 and J14

DIP Switches SW3 and SW4 are shown in the factory default position that causes the relays to be closed (shorted) when there is an Alarm. To cause the relays to OPEN when there is an Alarm (this is unusual), set all switches to OFF.



Outdoor Donor Antenna

Figure 10. Antenna Monitor Connection Diagram

Items Not Supplied

QTY	Part Number	Description	Suggested Supplier
1	ZNBT-60-1W+	Bias -T	www.Minicircuits.com
1	PL-CN01-2	BNC male plug to AV 2 screw	AMAZON.com

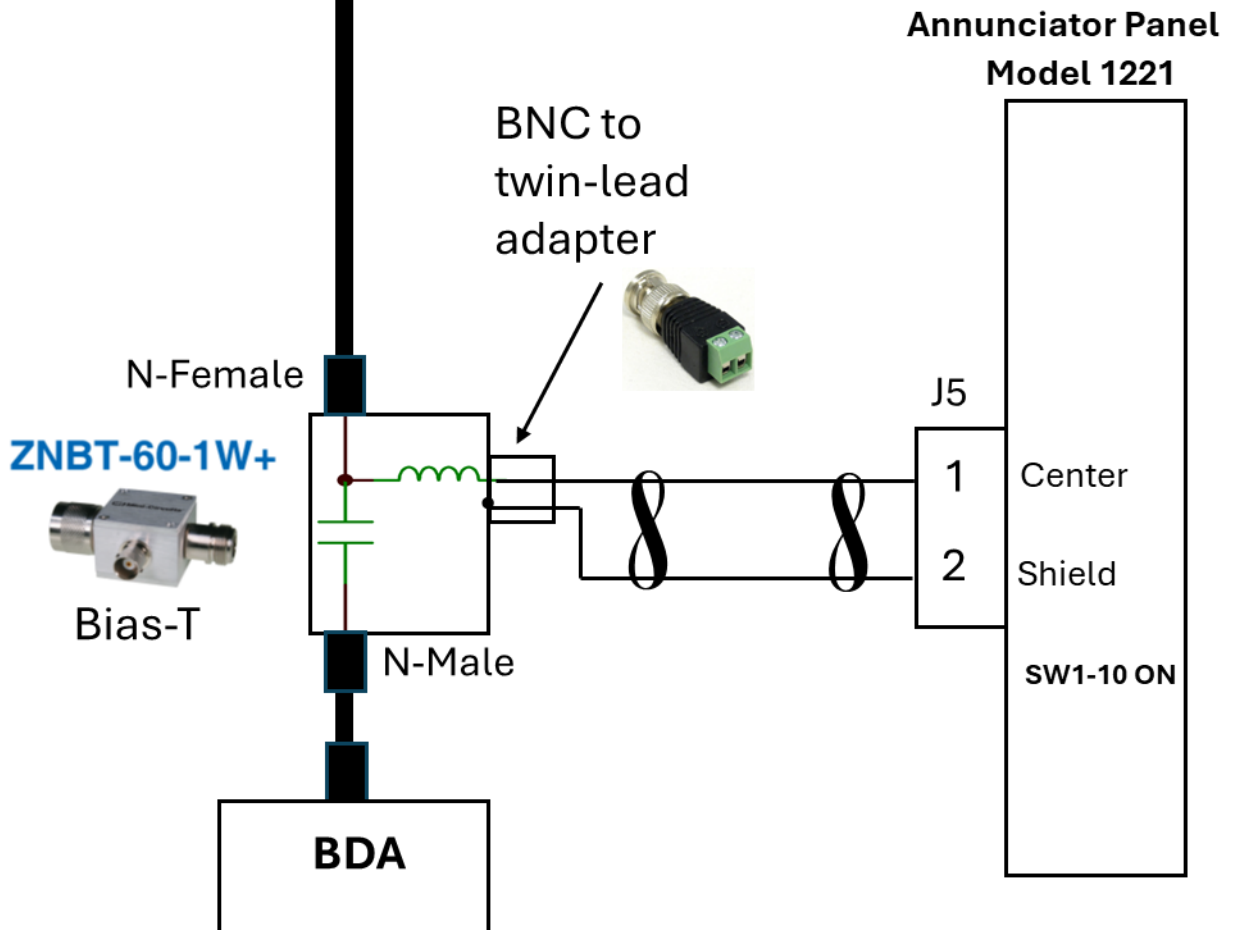

Figure 11. Optional Active Headend Alarm Splitter to Enable Easy Connection of DAS Components to both the Building's Fire Panel, Remote Modules and the DAS Alert Panel (includes LED Indicators and audible alarm Buzzer)

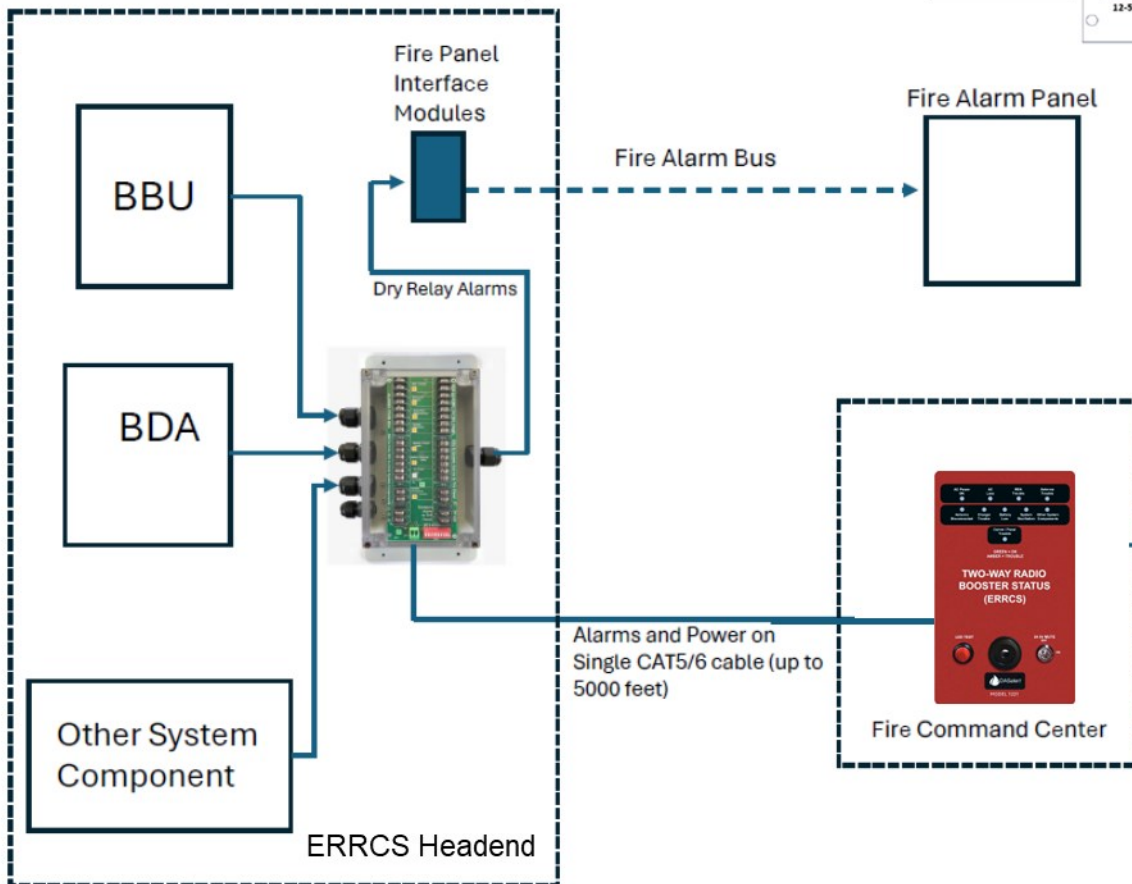
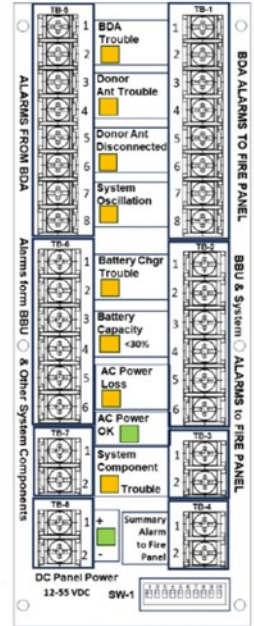

Figure 12. Back of Door

This LED is Green when DC power to the Panel is ON

This LED Flashes Green when DC power to the Panel is OFF and the AA batteries are providing backup power to the Panel.

This LED Flashes Red if the AA batteries are not installed correctly or battery pack is discharged to below 4.5 VDC. Supervision of these batteries can be disabled by turning ON DIP switch SW1 #9

Battery Pack Test Point

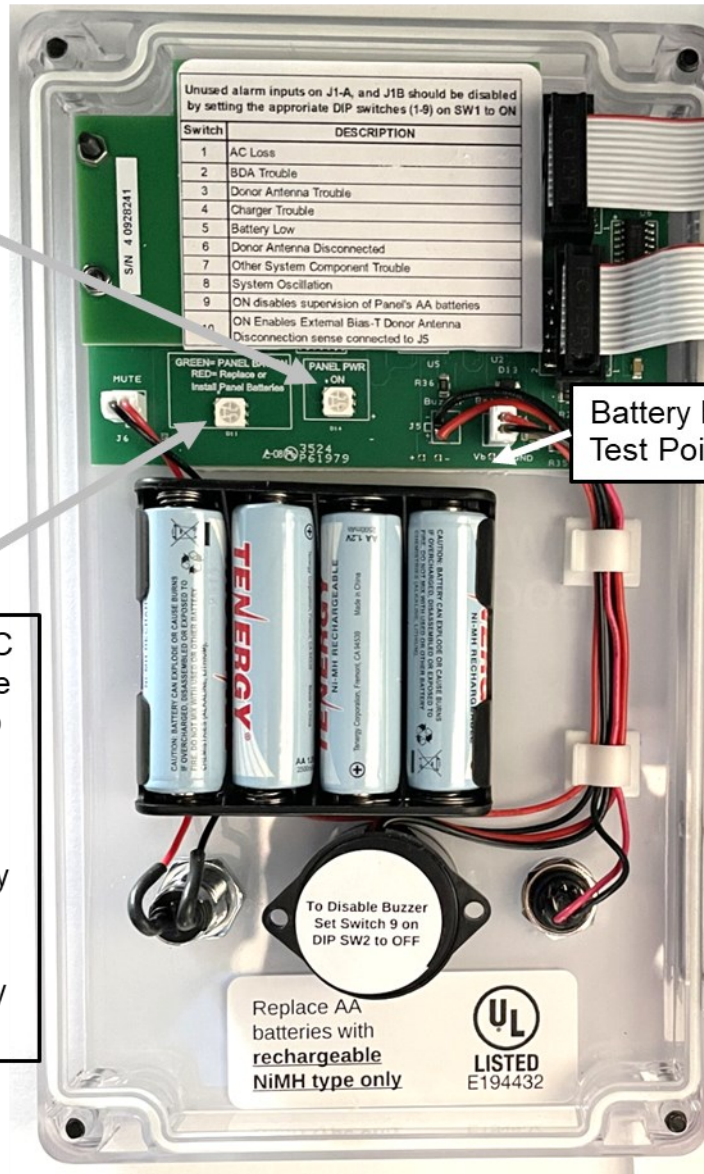
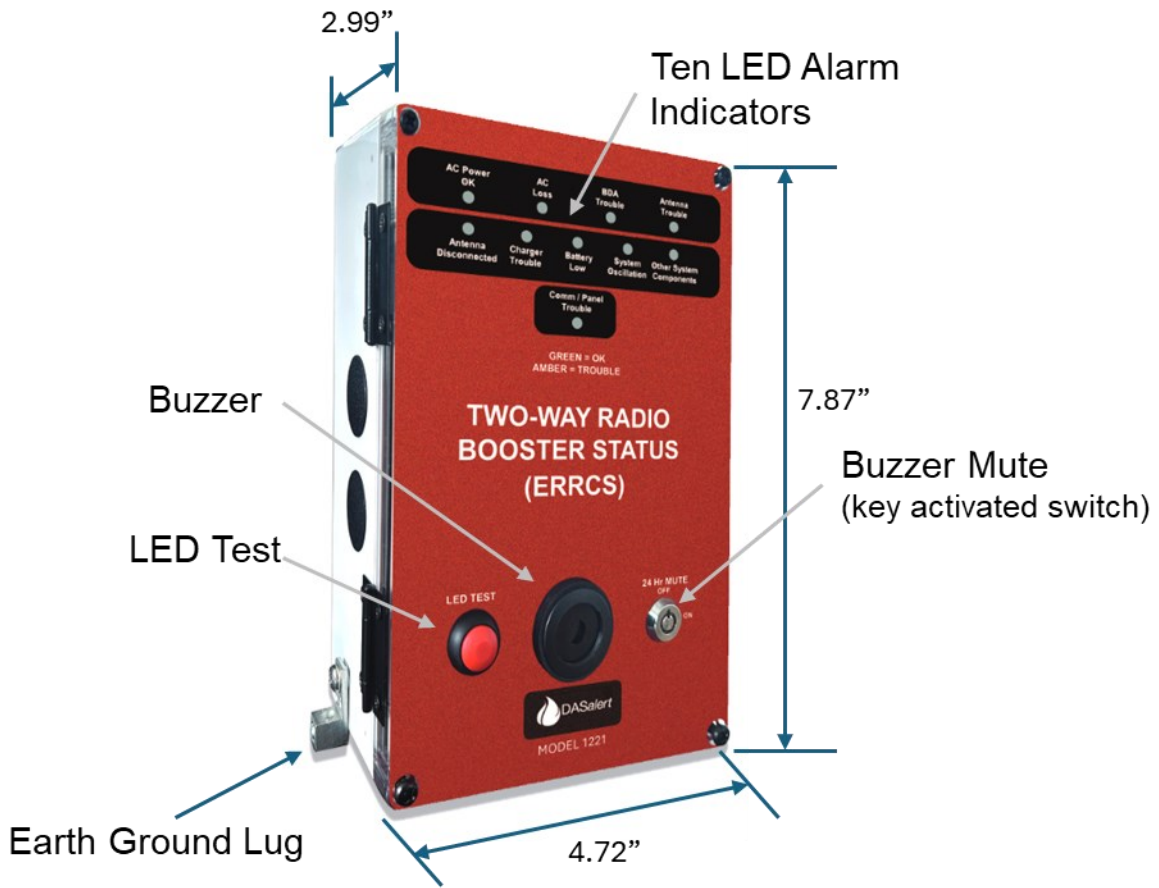

Figure 13. Physical Dimensions



Specifications

Visible Annunciators	
Normal AC Power	Green when AC power is normal, off when AC power is bad
Loss of Normal AC Power	Normally off, amber indicating alarm
BDA Trouble	Normally off, amber indicating alarm
Donor Antenna Malfunction	Normally off, amber indicating alarm
Donor Antenna Disconnection	Normally off, amber indicating alarm
DAS Backup Battery Charger Failure	Normally off, amber indicating alarm
Loss of DAS backup Battery Capacity to 70% Depletion	Normally off, amber indicating alarm
System Oscillation	Normally off, amber indicating alarm
Other System Component Malfunction	Normally off, amber indicating alarm
Communications and Panel Status	Normally off, amber indicating alarm
Audible Annunciator	Triggers every 10 seconds when any alarm condition exists
Mute Key Switch	Silences audible alarm for up to 24 hours when activated

Alarm inputs from DAS Equipment Relays	
Loss of normal AC Power	2 or 1 wire input
BDA Trouble	2 or 1 wire input
Donor Antenna Malfunction	2 or 1 wire input
Donor Antenna Disconnection	2 or 1 wire input
DAS Backup Battery Charger Failure	2 or 1 wire input
Loss of DAS Backup Battery Capacity to 70% Depletion	2 or 1 wire input
System Oscillation	2 or 1 wire input
Other System Component Malfunction	2 or 1 wire input

Cable Connection from DAS Head End to Panel	Standard CAT5 or CAT 6 cable
Max Cable Length	5000 feet
Optional Fiber Interface	Carries all alarms on a single fiber (single mode or multimode). Max distance 20 km

Specifications...Continued

Relay outputs to building's fire panel	Single-pole-double-throw relays, 0.2 Amps max, 30 VDC max
Loss of Normal AC Power	
BDA Trouble	
Donor Antenna Malfunction	
Donor Antenna Disconnection	
DAS Backup Battery Charger Failure	
Loss of DAS Backup Battery Capacity to 70% Depletion	
System Oscillation	
Other System Component Malfunction	
Communications Trouble	
Panel Battery Bad or not Installed	
Panel Power Loss	
Summary Fault	

Power Requirements:	
Supplied 48 VDC power supply (120 VAC input) or user supplied DC power between 12 -55 VDC	60 mA @ 24 VDC, 30 mA @ 48 VDC

Physical Characteristics (see Figure 13)	
Panel	4.72" W x 7.87" H x 2.99"D Weight: 1.75 Lbs
Optional in-wall mounting Surround	8" x 11"

Meets or exceeds the following specifications:	
UL-2524	
NFPA 72	
NFPA 1225	
IFC	
IEC320-C14	
UL60950-1	
NEMA-4	
UL listed E194432 (control panel)	